



GIANT[®]
BY TOBROCO



COMPACT DESIGN
BIG IN PERFORMANCE

G2200E



GERÄUSCHARM



EMISSIONSFREI



LITHIUM-IONEN BATTERIE



LEISTUNGSSTARK



ENERGIERÜCKGEWINNUNG

WWW.TOBROCO-GIANT.COM

TECHNISCHE DATEN

TYPE	G2200E	G2200E X-TRA
Betriebsgewicht ¹	2.200 kg	2.200 kg
Hubkraft	1.650 kg	2.200 kg
Kipplast ²	1.450 kg	2.054 kg
ABMESSUNGEN UND FAHRGESCHWINDIGKEIT		
Hubhöhe ²	2.825 mm	2.450 mm
Gesamtlänge ohne Schaufel	2.975 mm	3.054 mm
Durchfahrhöhe ³	2.300 mm	2.300 mm
Breite auf Serienbereifung	1.080 mm	
Standardbereifung	10.0/75x15.3 AS	
Fahrgeschwindigkeit	0-20 km/h	
STANDARD BATTERIE		
Lithium-ionen batterie	260Ah / 48V (195 kg)	
Standard on board-Ladegerät	230V / 40A	
Ladezeit	5 Stunden	
FAHRANTRIEB		
Elektromotor Arbeitshydraulik	6,5 kW	
Energierückgewinnung	Automatisches Aufladen der Batterie, z.B. wenn sie ausrollt oder bergab fährt.	
Type	Elektrischer Allradantrieb mit Gelenkwelle	
Differential	Differentialgetriebe mit Sperwirkung in beiden Achsen	
Zugkraft	12.500 N	
Hill-Hold-Funktion	Anfahrthilfe verhindert das Zurückrollen am Hang	
Handbremse	Trommelbremse	
ARBEITSHYDRAULIK		
Elektromotor Arbeitshydraulik	12 kW	
Arbeitshydraulik	35 l/min (170 bar)	

SERIENAUSSTATTUNG

	G2200E	G2200E X-TRA
Werkzeugaufnahme hydraulisch	Std	Std
Hydraulikkreislauf (doppeltwirkend) mechanisch bedient	Std	Std
ROPS / FOPS Fahrerschutzdach inkl. Sicherheitstüren links und rechts	Std	Std
Hydraulische Betriebsbremse	Std	Std
Mechanisch gefederter, verstellbarer Komfortsitz mit Sicherheitsgurt und Armlehne	Std	Std
Zugmaul	Std	Std
Zusätzlicher Arbeitsscheinwerfer (LED) vorne	Std	Std
Batteriemanagementsystem	Std	Std
Diebstahlschutz mit Zugangscode (nicht zertifiziert)	Std	Std

¹ Gemessen mit Erdbauschaufel ² Gemessen im Drehpunkt, Maschine gerade, mit Standardbereifung ³ Gemessen auf Standardbereifung und Fahrerschutzdach

KIPPLASTEN

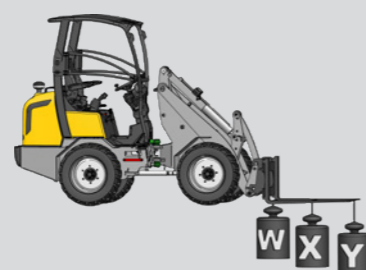

	G2200E	G2200E X-TRA
S	1.450 kg	2.054 kg
T	1.250 kg	1.580 kg
U	950 kg	1.140 kg
V	745 kg	850 kg
W	2.000 kg	2.675 kg
X	1.270 kg	1.590 kg
Y	1.000 kg	1.120 kg

BATTERIE OPTIONEN

Lithium-ionen batterie	48V
Nennkapazität	390 Ah
Nennkapazität	520 Ah

LADESYSTEME OPTIONEN

On board-Ladegerät	230 V / 60 A
Ladezeit standard Batterie	5 Stunden
Externes Ladesystem (260 Ah Batterie)	48 V / 150 A
Ladezeit 260 Ah battery	3 Stunden
Externes Ladesystem (260 Ah Batterie)	48 V / 300 A
Ladezeit 260 Ah Batterie	1,5 Stunden



ABMESSUNGEN

	Einheit	G2200E	G2200E X-TRA
A Radstand	mm	1.515	1.580
B Gesamtlänge	mm	2.975	3.054
C Gesamtlänge mit Schaufel	mm	3.690	3.830
D Länge der 3-Punkte Anhängerkupplung	mm	622	622
E Kupplung in niedrigster Position	mm	134	134
F Kupplung in höchster Position	mm	797	797
G Sitzhöhe	mm	1.256	1.256
H Höhe mit Fahrerschutzdach	mm	2.300	2.300
I Höhe mit Kabine	mm	2.284	2.284
J Höhe Vorderwaagen	mm	1.480	1.250
K Ausschütthöhe	mm	1.988	1.680
L Überladehöhe	mm	2.825	2.450
M Gesamtarbeitshöhe	mm	3.392	3.040
N Einkippwinkel am Boden	graden	43	41
O Einkippwinkel in max.Höhe	graden	53	46
P max. Auskippwinkel	graden	47	37
Q max.Steigwinkel	graden	29	29
R Innenmaß der Reifen	ø mm	760	760
1D Gesamtbreite auf Standard Reifen	mm	1.080	1.080
1A Radius mit Schaufel	mm	2.599	2.650
1B Radius am Außenrand	mm	2.292	2.342
1C Innenradius	mm	1.179	1.230

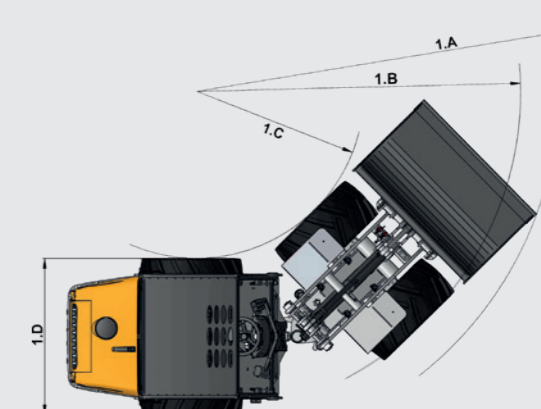
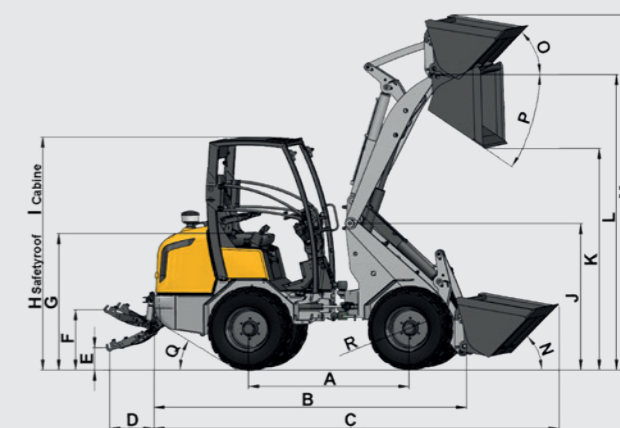

EINE MASCHINE FÜR ALLE IHRE ARBEITEN!



STRASSENBAU



LANDWIRTSCHAFT



BAUWIRTSCHAFT & ABBRUCH



PFERDEHALTUNG



FORSTWIRTSCHAFT



KOMMUNEN



MATERIALTRANSPORT



BAUMSCHULEN



WINTERDIENST



GALABAU

